

Operating Manual

HPP13 FLEX Hydraulic Power pack

From serial
number 13671

Revised
15.12.2018

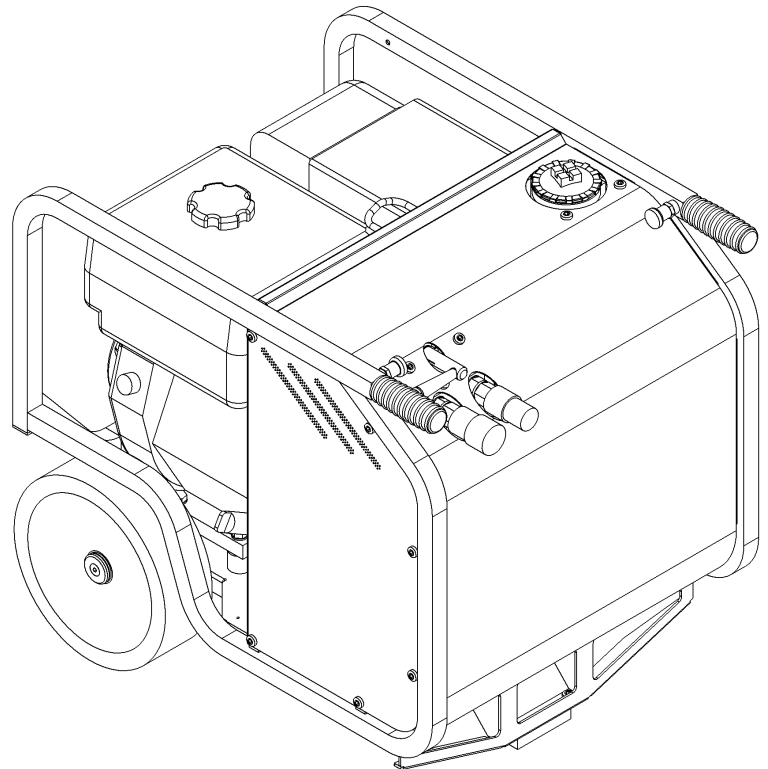

Prior to Operation

We thank you for choosing a HYCON powerpack.

Please note that the power-pack is delivered without hydraulic oil, and therefore it must be filled up with hydraulic oil prior to operation.

To ensure smooth operation and long-lasting performance of your new powerpack, we recommend that you study this operating manual carefully and pay special attention to the

Safety and Service Precautions

We hope you will be satisfied with your new HYCON power-pack.

Best regards
HYCON A/S



HYCON A/S
Juelstrupparken 11
DK-9530 Støvring
Denmark

Tel: +45 9647 5200
Fax: +45 9647 5201
Mail hycon@hycon.dk
www.hycon.dk

Contents

	Page
Safety Precautions.....	2
Filling up Hydraulic Oil	2
Technical Data	3
Starting Instructions	4
Service, Maintenance and Hydraulic Settings.....	5
Oil Types	6
EC-Declaration of Conformity	7
Warranty Terms	8
Spare Parts List.....	9

Safety Precautions

1. Always use protective earplugs. The powerpack complies with the EU noise limits, but by daily long-lasting operation there is a risk of hearing defects.
2. Always connect hoses before starting.
3. Never add fuel and oil when the engine is running.
4. In case of non-operation or performance of service, always turn off the engine.
5. Never start the engine without side covers.
6. Operation of the powerpack without tool connected and with lever at "ON" may cause overheating of the system and damage to the powerpack.
7. When lifting the powerpack from a vehicle, we recommend the use of a crane.
8. The pressure relief valve is set at 150 bar from our plant. Never set it higher.
9. Always use filters with by-pass. The use of filters without by-pass may blow the hydraulic hoses and the filter cover.

Filling Up Hydraulic Oil

- To fill up with hydraulic oil, loosen the filter cover on top of the powerpack.
- Remove the filter element (see photo), and fill up with oil. When oil is showing at the bottom of the filter unit, there is enough oil on the powerpack.
- Insert the filter element again, mount the cover and the powerpack is ready for use.

Please note: When connecting new extension hoses, it is necessary to fill up with extra 2 litres of oil. Therefore always top up the powerpack when connecting new extension hoses.



Technical Data

Hydraulics

The HYCON HPP13 open centre hydraulic powerpack is designed in accordance with the EHTMA categories C and D, which prescribe a minimum performance of 20 l.p.m. at 138 bar and 30 l.p.m. at 138 bar, respectively.

With manual flow adjustment. This powerpack can be set to 20 to 30 l.p.m. on the front of the powerpack.

The powerpack is mounted with a pressure relief valve to avoid a too high pressure. Furthermore, the very efficient air cooling protects the powerpack against overheating.

Oil flow	20 l.p.m. at 2500 r.p.m. 30 l.p.m. at 3600 r.p.m.
Working pressure nominal	120 bar
Pressure relief valve	Set at 150 bar
Pump	Gear pump
Oil temperature	Max. 70° C
Hydraulic oil tank capacity	Min. 6 litres/max. 8 litres
Petrol tank capacity	6.5 litres
Hydraulic system compl.	9 litres
Filter system (filter element)	25 Micron with by-pass
Engine	Honda GX390QXB7 13 HP (gross power) 4-stroke petrol with oil alert system Petrol - normal or unleaded Engine oil 1.1 litres
Guaranteed sound power level L_{WA}	101 dB
Sound pressure level 1 m L_{PA}	89 dB
Dimensions (LxWxH)	710x595x645 mm
Weight, without hydraulic oil	81 kg

Starting Instructions

Please observe the starting instructions on the front of the powerpack.

- Start:**
- Check engine oil level
 - Check hydraulic oil level at sight glass
 - Connect hoses and tool
 - Switch fuel tap to "ON"
 - Activate choke
 - Turn ignition switch to "1"
 - Pull recoil starter
 - Move the lever to the desired flow
- Stop:**
- Move the lever to "OFF"
 - Turn off the ignition switch
 - Turn the fuel tap to "OFF"

Powerpack with adjustable flow:

The desired oil flow can be set on the front of the powerpack. A marking is engraved in the lever.

Turn the lever to the right until the marking is opposite the required flow

The pressure relief valve setting will be the same on all flows.



Service, Maintenance and Hydraulic Settings

Service/Maintenance	Daily	Weekly	Yearly
Engine oil	Check		1 x replacement
Hydraulic oil	Check		1 x replacement
Hydraulic oil filter *)			1 x replacement
Check hoses		(tighten up if needed)	
Air filter			1 x replacement
Fuel filter			1 x replacement

*) Use only filters with by-pass

Hydraulic Settings

Check the working pressure by means of test equipment. The test equipment must comprise a pressure gauge, a flow meter and a valve for adjustment of pressure.

The pressure relief valve is placed on the right side of the valve block.

1. Connect the test equipment, start the powerpack and move the lever to "ON". Then close the valve - the pressure gauge must show 150 bar.

Adjust the pressure relief valve by loosening the lock nut and turning the adjustment screw in or out. "In" increases the pressure, and "out" decreases the pressure.

Retighten the lock nut after adjustment.

2. When the pressure relief valve has been adjusted correctly, the working pressure must be set at 100 bar by means of the valve on the test equipment. At 100 bar, the oil flow should be 20 (30) l. p.m.

On the powerpack with adjustable flow, the flow is regulated by adjusting the position of the throttle cable.

If correct pressure/oil flow cannot be achieved by following the above instructions, the powerpack must be re-adjusted. If the pressure/oil flow is then still incorrect, the pump is defect and must be replaced.

Oil Types

The HYCON powerpack uses standard hydraulic oil, i.e. all types of mineral oil and biodegradable oil, which comply with the following values:

Recommended viscosity	20-40 cSt
Permitted viscosity	15-1000 cSt
Viscosity index	Min. 100
Temperature area	-20° to +70° C



EC-Declaration of Conformity

HYCON A/S
Juelstrupparken 11
DK-9530 Støvring
Denmark

Tel: +45 9647 5200
Fax: +45 9647 5201
Mail hycon@hycon.dk
www.hycon.dk

We hereby declare that

HPP13 hydraulic powerpack – from serial No. 13671
(with 9.75 kW petrol engine)

is manufactured in conformity with the EC Directives 2006/42/EC and 2000/14/EC.

Notified Body 1585:

AkustikNet A/S
Frederikssundsvej 179 B
DK-2700 Brønshøj
Denmark

Guaranteed sound power level: 101 dB

HYCON A/S
Juelstrupparken 11
DK-9530 Støvring
Denmark

A handwritten signature in blue ink, appearing to read "Martin Møller".

Martin Møller
Managing Director

15.12.2018

Warranty Terms

We grant 12 months warranty from the first date of operation – however, not more than 18 months from the date of delivery.

The warranty applies to faults that can be related to construction and production errors.

Faults caused by incorrect operation, incorrect handling, lack of maintenance or the like will not be accepted as warranty.

The warranty covers the parts necessary for repair and the suggested average time needed for repair.

For further warranty details, please contact your local dealer.